

Ora Monitor Arm C-clamp

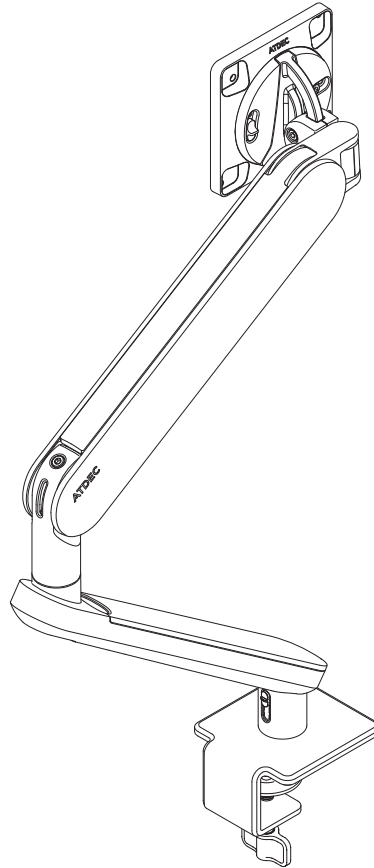

FEATURES

- Complete, fully featured monitor arm for a single curved or flat display up to 35".
- Balanced tilt mechanism for dynamic viewing angle selection.
- Effortless counterbalance adjustment with an easy-to-read gauge for fast bulk deployments.
- Integrated, toolless 180° arm rotation limiter to prevent interference with walls and workstation dividers.
- Adjustable portrait-to-landscape rotation tension.
- Contemporary styling to suit modern workplace interiors.
- Discreet cable management guides cables down the arm to the work surface.
- Supplied with desk clamp, dynamic arm, VESA plate, and display mounting fasteners.
- Compatible with AW-FB Ora Bolt Through Fixing (sold separately).

Display weight	2-8kg* (4.4-17.6lb)
Display size	Up to 35"+ (Curved or Flat)
Tilt adjustment	+45° / -20°
Rotation adjustment	+/- 90°
Horizontal adjustment	645mm (25.4")
Vertical adjustment	315mm (12.4") Dynamic
VESA mounting	75x75 100x100
Worksurface thickness	18-40mm (¾-1 ½")
Primary materials	Aluminium, Steel, Engineering Polymers

* Deep devices (such as all-in-one PCs) and offset VESA locations exert additional leverage that can exceed the capacity of the mount even though the monitor weight may be within the stated range. Please contact Atdec if you would like further information.

† Larger monitors within the weight capacity may be compatible, please contact Atdec for advice.

WARRANTY

10 years limited

MOVEMENT | DYNAMIC ARM

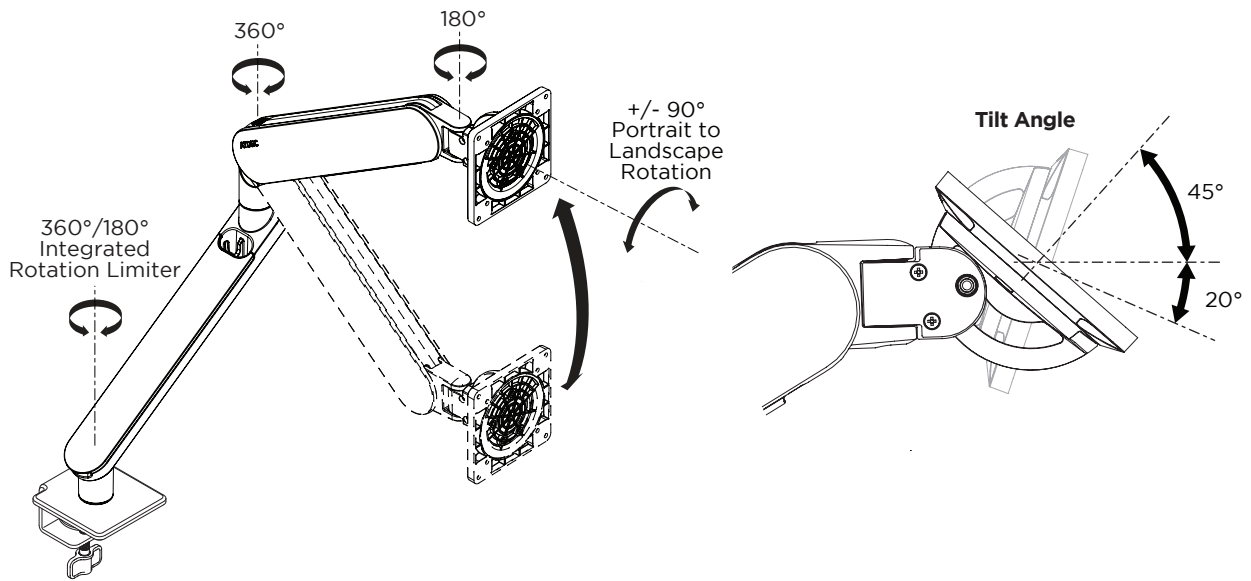

DIMENSIONS | DYNAMIC ARM

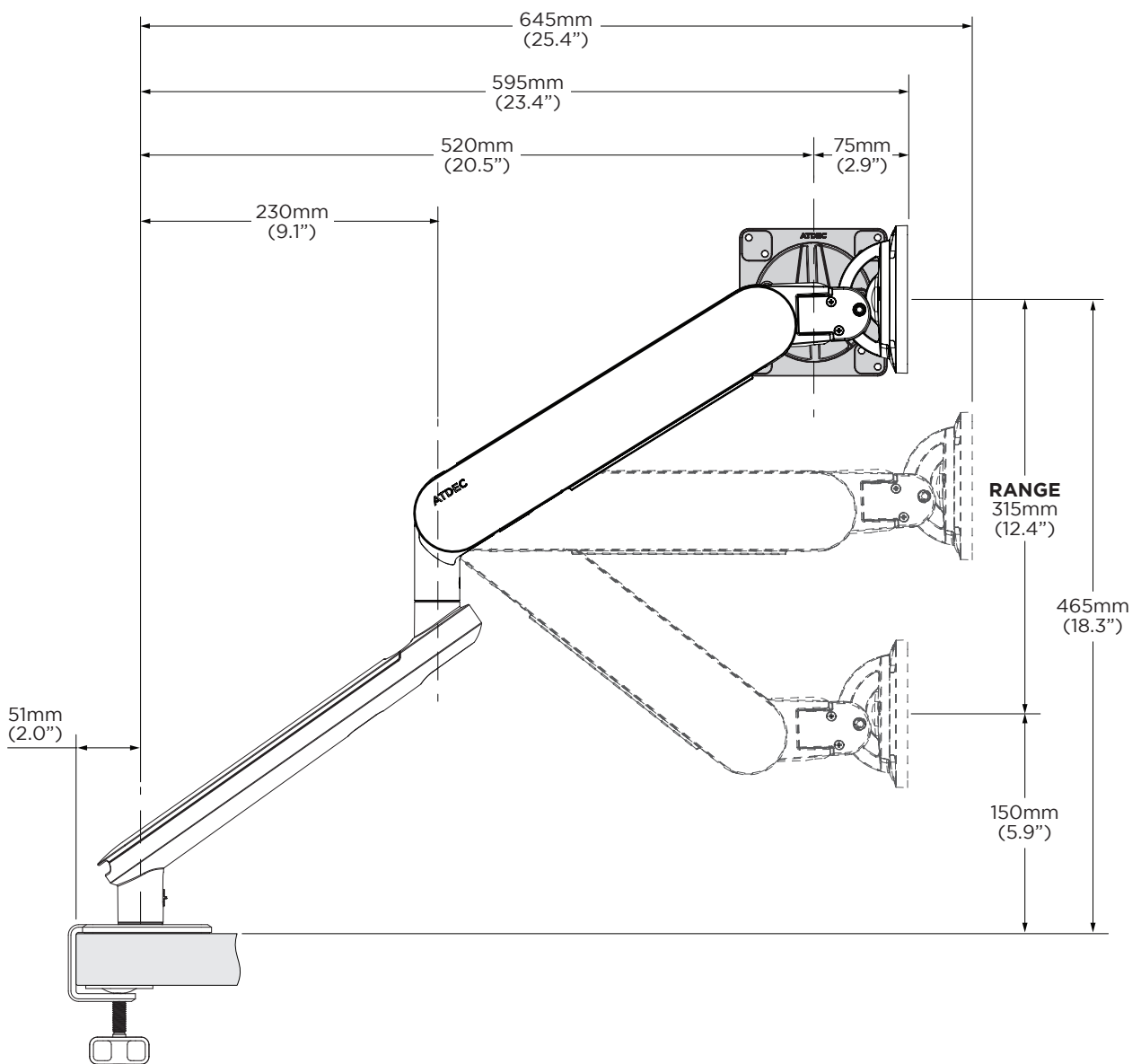

DIMENSIONS | DYNAMIC ARM

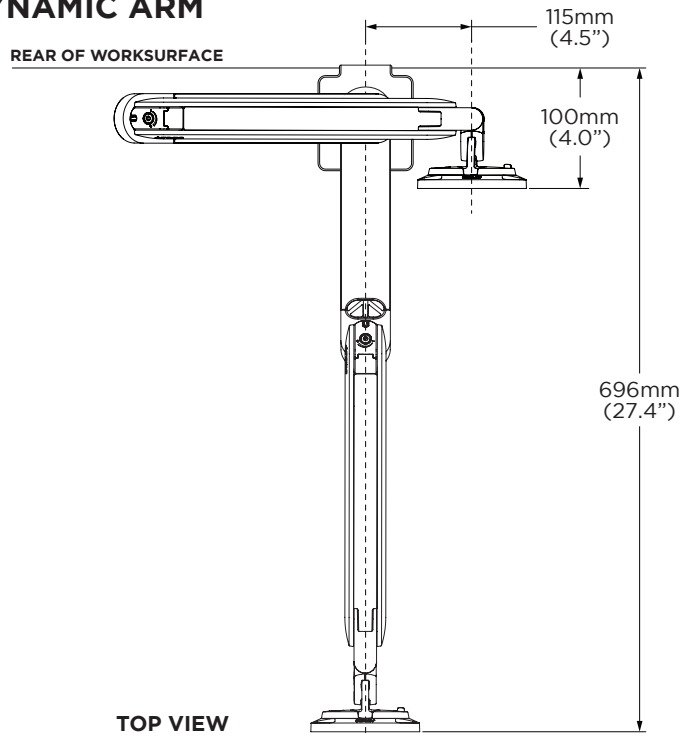

DIMENSIONS | INDICATIVE POSITIONING FOR DUAL DISPLAYS*

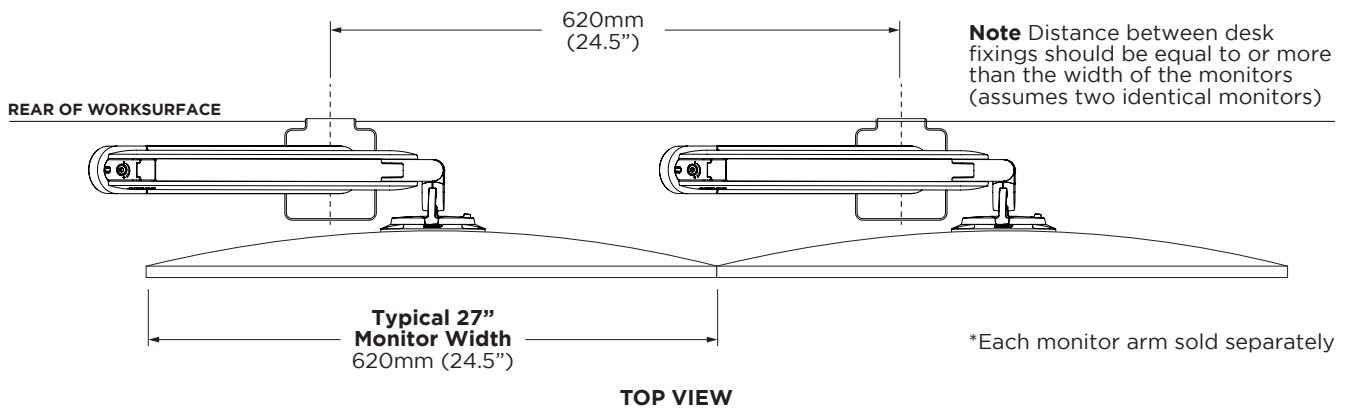

DIMENSIONS | VESA HEAD

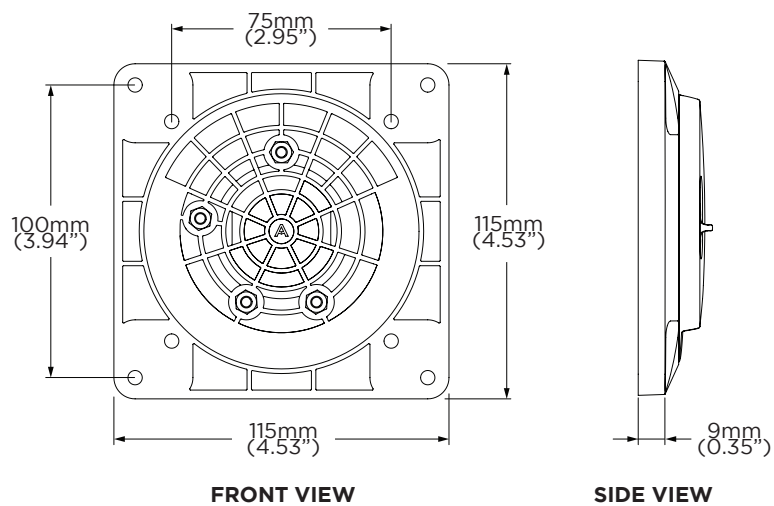

DIMENSIONS | C-CLAMP

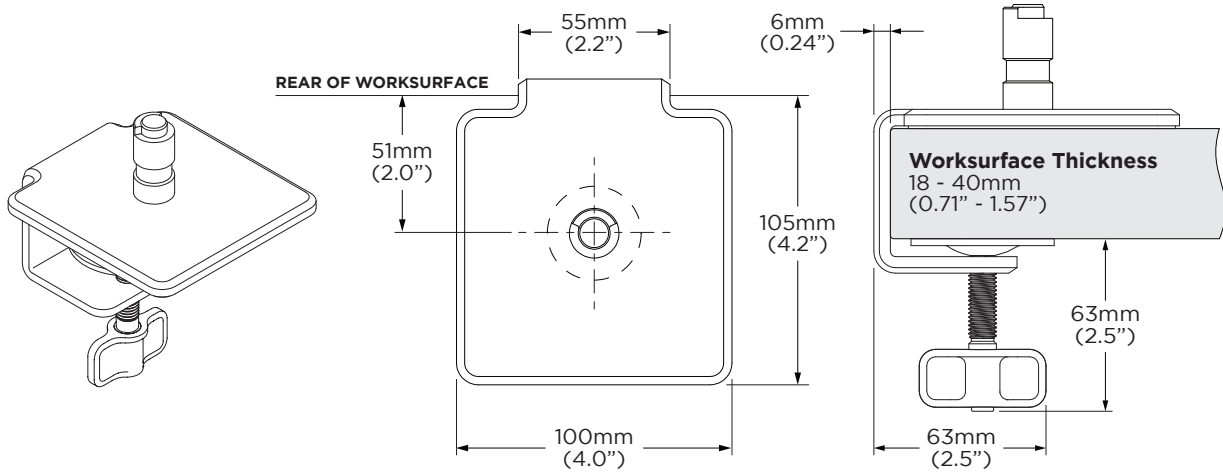

DIMENSIONS | AW-FB ORA BOLT THROUGH FIXING (SOLD SEPARATELY)

