

F Clamp

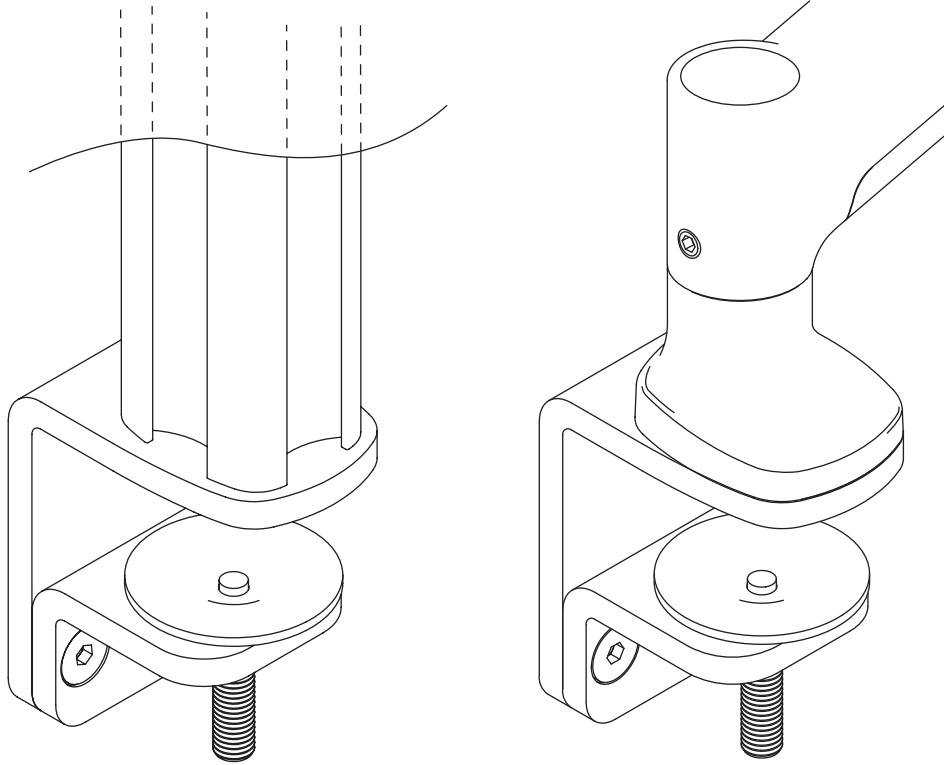

COMPONENT CHECKLIST

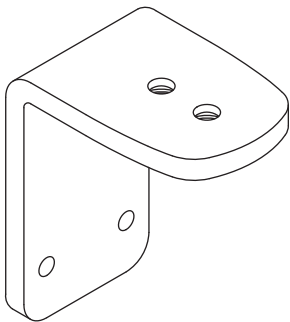

A
Upper Clamp
(x1)

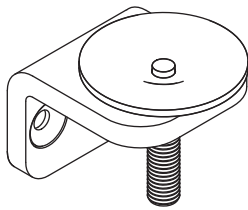

B
Lower Clamp
(x1)



C
Screw
M8 x 16mm
(x2)

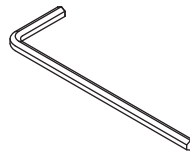

D
5mm
Hex Key
(x1)

Desk 

REQUIRED TOOLS

- All tools provided

IMPORTANT INFORMATION

- ! Please ensure this product is installed as per these installation instructions.
- ! This product is compatible with Atdec AWM Series products.
- ! The manufacturer accepts no responsibility for incorrect installation.
- ! Product must only be installed on a work surface capable of supporting the weight of all equipment being mounted.
- ! Product is not suitable for installation on work surfaces with a bullnose or bevelled edge.

1. Attach post or base to upper clamp

1.1 Option A - Attach post to upper clamp

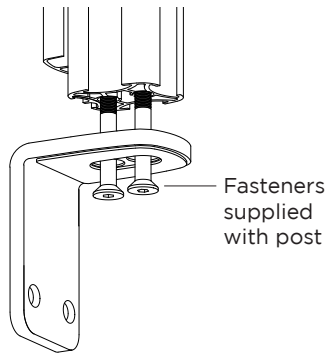

Note: post sold separately

1.2 Option B - Attach base to upper clamp

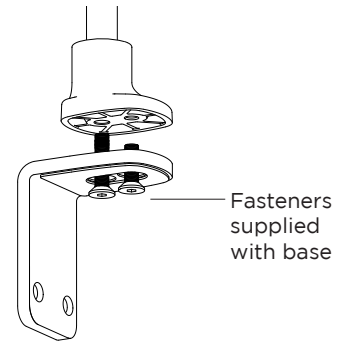

Note: base sold separately

2. Attach lower clamp to upper clamp

2.1 Measure the worksurface thickness and choose the suitable lower clamp position

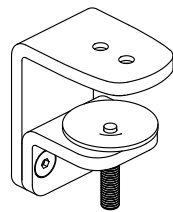
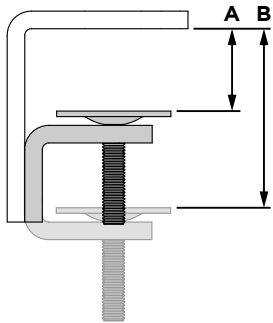

A - Normal
0 - 36mm
(0.00 - 1 3/8")

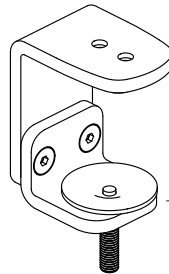

B - Inverted
36 - 79mm
(1 3/8" - 3")

2.2 If using inverted position change the screw direction of the lower clamp

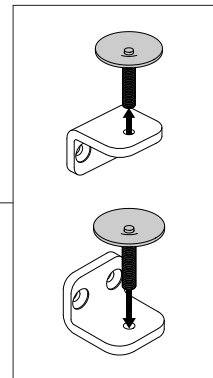

2.3 Attach lower clamp to upper clamp in the suitable position using the two provided screws. (Normal position shown here)

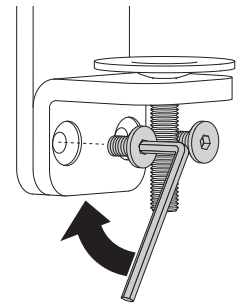

Note: If there is only a small gap behind the worksurface, perform **Step 3.1** before this step.

3. Fit fixing to work surface

3.1 Place in desired location on worksurface

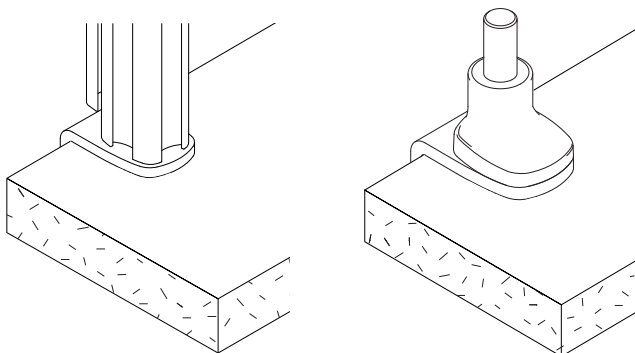

Post Installation

3.2 Screw in pressure plate and **tighten firmly.**

