

Dual Dynamic Monitor Arms on 400 Post

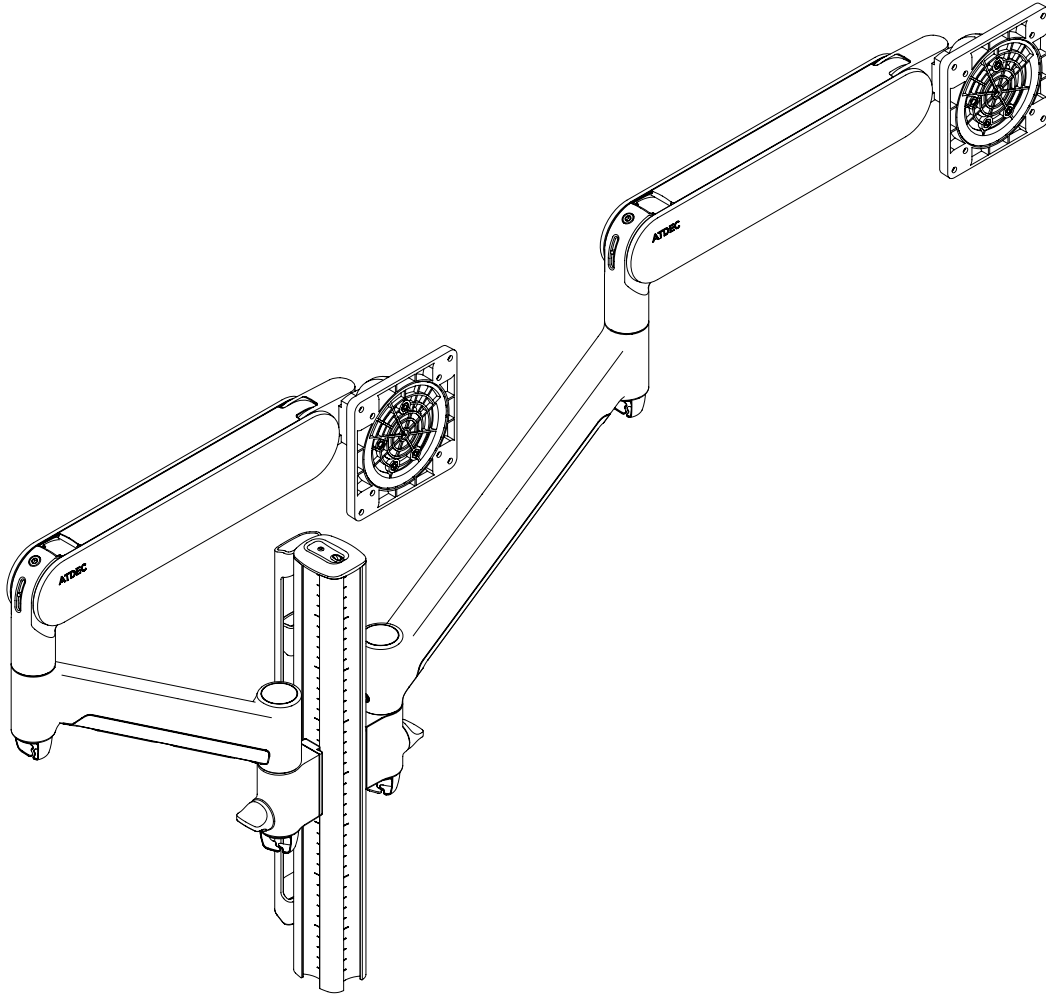

FEATURES

- Dual display mounting solution to suit most displays up to 27". Larger monitors within the weight capacity may be compatible, refer to Monitor Size (page 2).
- Balanced tilt mechanism for dynamic viewing angle selection.
- Effortless counterbalance adjustment with an easy-to-read gauge for fast bulk deployments.
- Display quick connect mechanism.
- Integrated 180° rotation limiter to prevent interference with walls and workstation dividers.
- Adjustable portrait-to-landscape rotation tension.
- Generous cable management guides cables discreetly down the arm to the work surface.

Display weight*

Flat display

2-8kg (4.4-17.6lb)

Curved display

2-8kg (4.4-17.6lb)

Display depth

Up to 140mm (5.5")

Tilt adjustment

+45° / -20°

Rotation adjustment

+/-95°

Vertical adjustment

633mm (24.9")

VESA mounting

75x75 100x100

Primary materials

Aluminium, Steel,
Engineering Polymers

* Deep devices (such as all-in-one PCs) and offset VESA locations exert additional leverage that can exceed the capacity of the mount even though the monitor weight may be within the stated range. Please contact Atdec if you would like further information.

WARRANTY

10 years limited

MOVEMENT DYNAMIC ARM

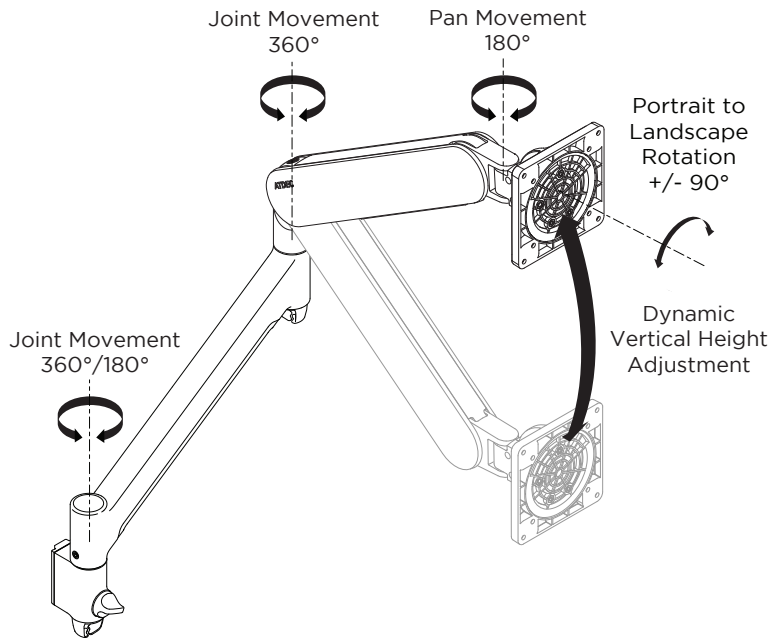

TILT ADJUSTMENT

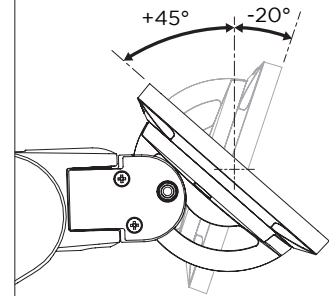

DIMENSIONS MONITOR SIZE AND POSITION

FLAT CONFIGURATION

REAR OF MOUNTING SURFACE

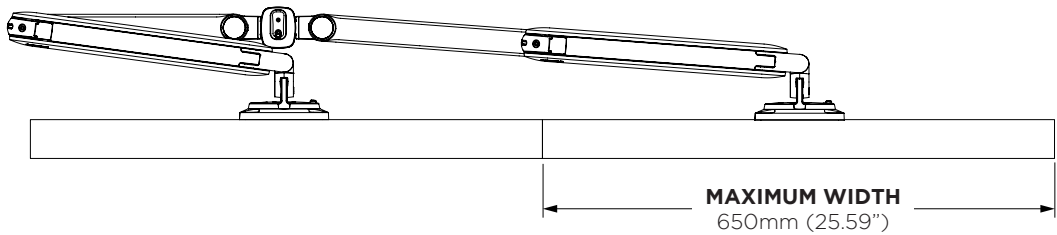

ASYMMETRICAL / PRIMARY & SECONDARY CONFIGURATION

REAR OF MOUNTING SURFACE

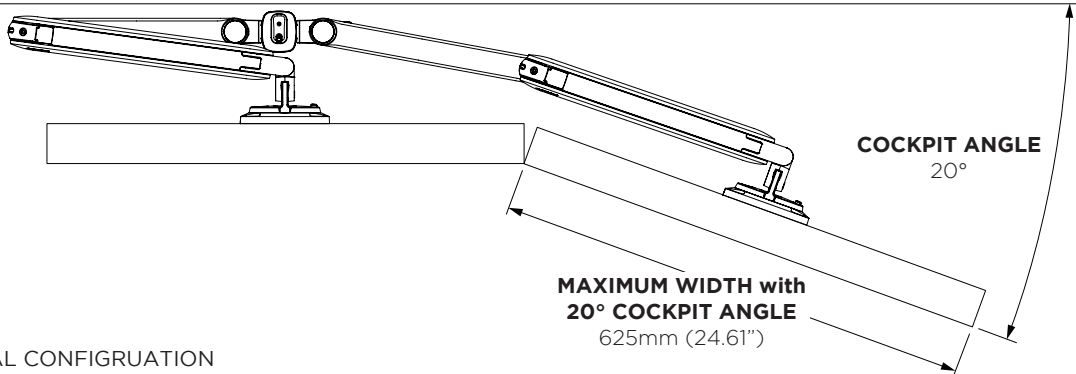

SYMMETRICAL CONFIGURATION

REAR OF MOUNTING SURFACE

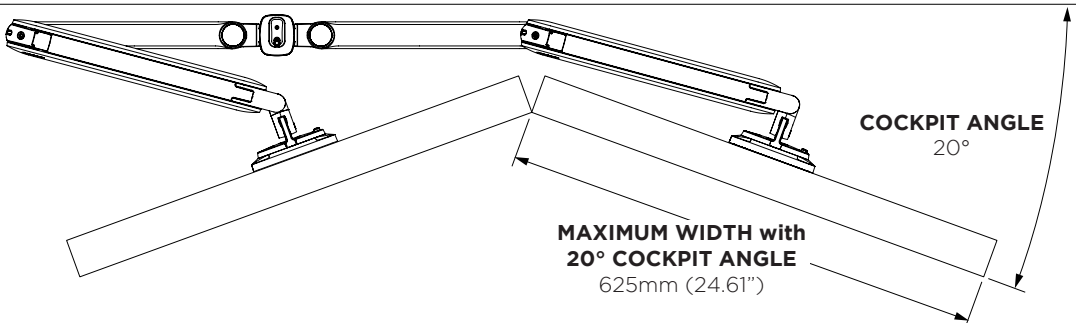

DIMENSIONS VESA HEAD

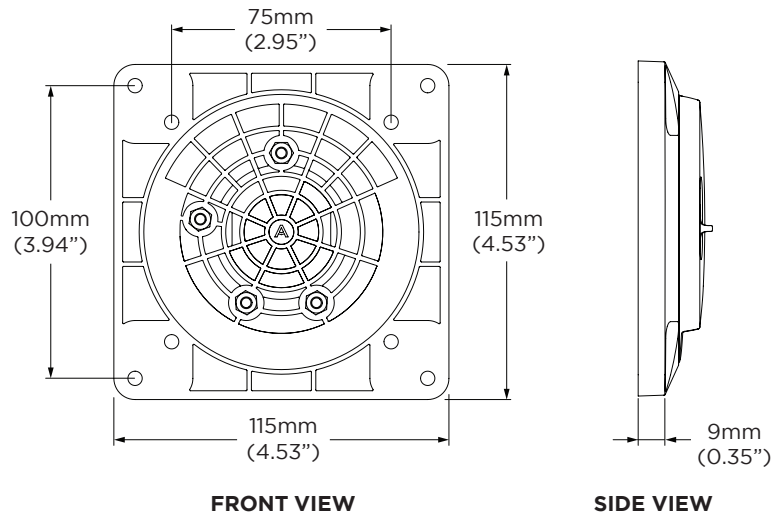

DIMENSIONS DYNAMIC ARM ON 400 POST

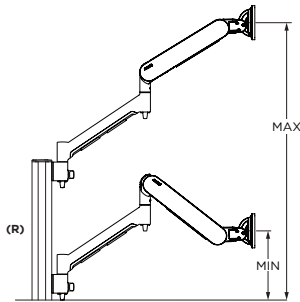

HEIGHT ON 400 POST	MIN	MAX	RANGE (R)
C CLAMP INCREASES MINIMUM HEIGHT ON POST BY 26MM (1")	209mm (8.23")	842mm* (33.15")	633mm* (24.92")

DIMENSIONS DYNAMIC ARM ON POST

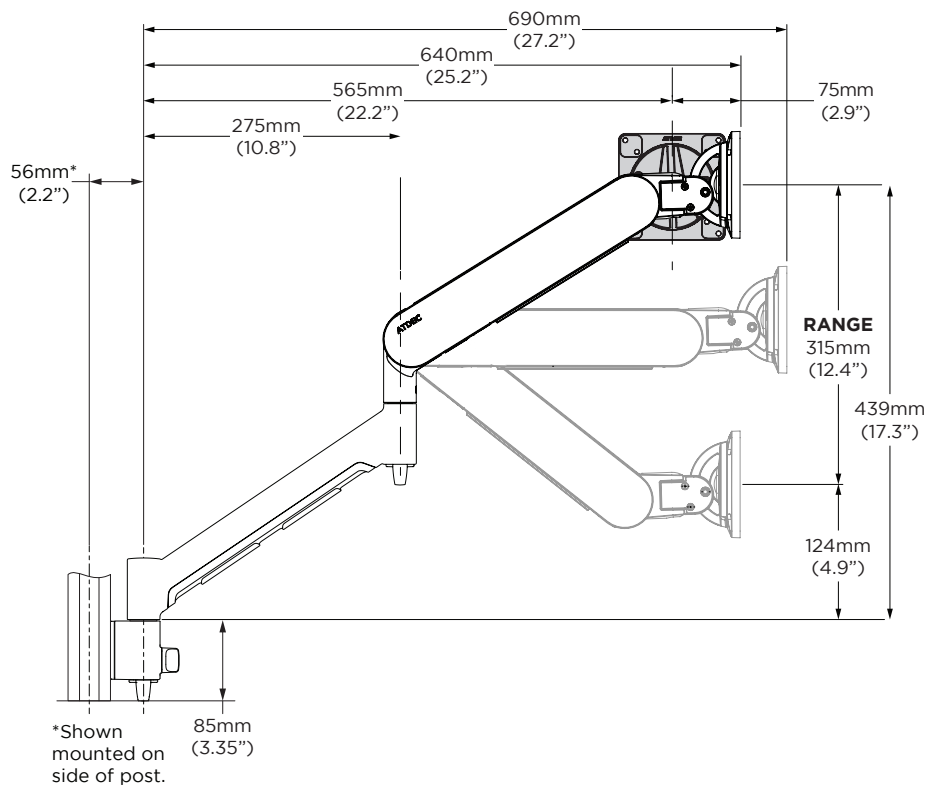

DIMENSIONS DYNAMIC ARM ON POST

Post Side Attachment

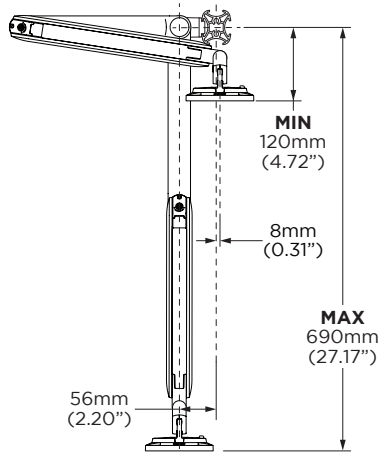

Post Front Attachment

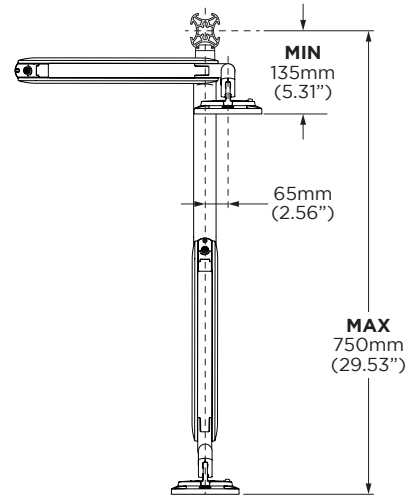

DIMENSIONS POSTS

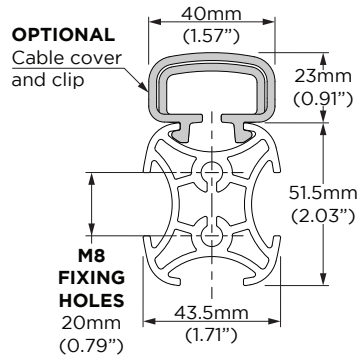

TOP VIEW

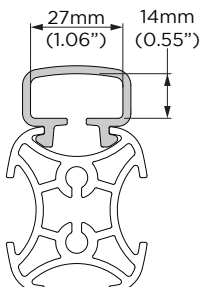

CABLE CLIP - TOP VIEW

NOTE Fits approximately six 7mm ($\frac{17}{64}$ ") cables

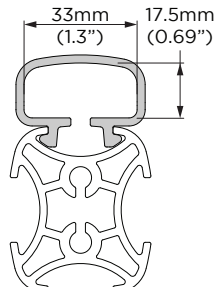

CABLE COVER - TOP VIEW

NOTE Fits approximately ten 7mm ($\frac{17}{64}$ ") cables

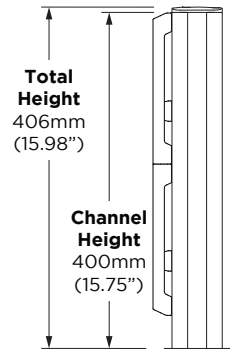
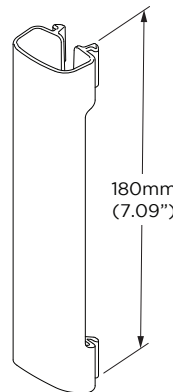

Compatible Fixings
Bolt Through Kit
 AWM-FB
C Clamp AWM-FC
F Clamp AWM-FF
HD F Clamp
 AWM-FH
Grommet Clamp
 AC-GC

DESK FIXING OPTIONS

Below are the fixing options available for this solution. For more information and detailed specifications for these products please see the separate Technical Specifications available on the Atdec website.

NOTE: Chosen desk fixing must be added to this solution code when ordering.

BOLT THROUGH AWM-FB

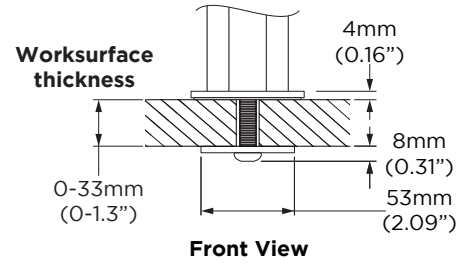
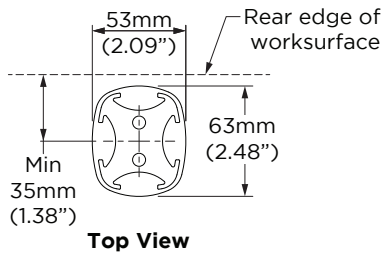
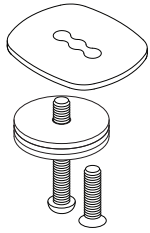

C CLAMP AWM-FC

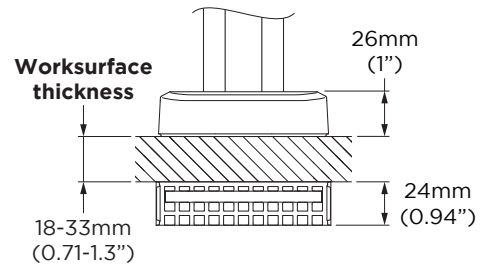
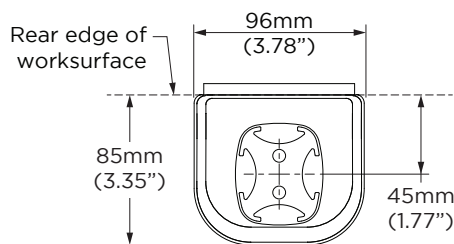
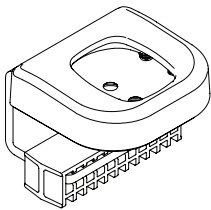

F CLAMP AWM-FF

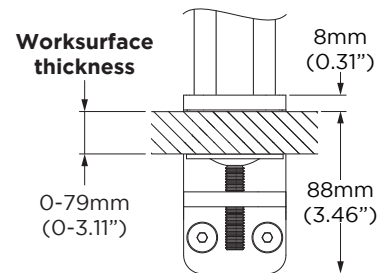
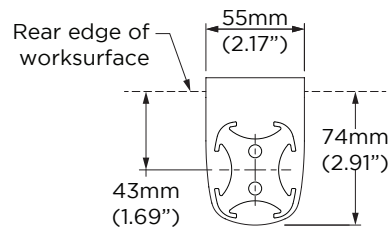
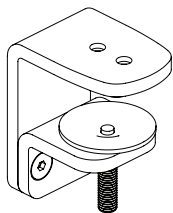

HEAVY DUTY F CLAMP AWM-FH

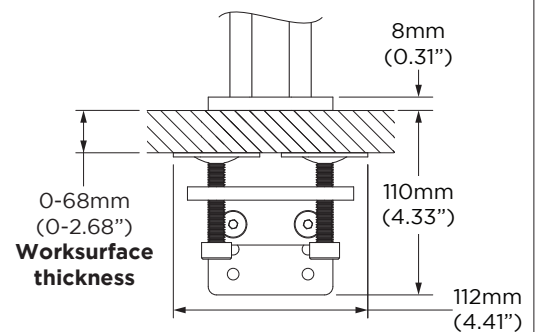
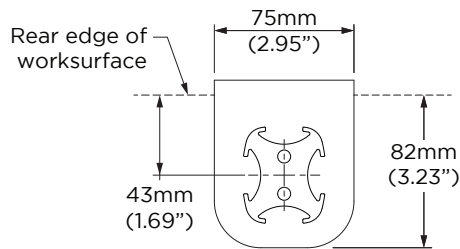
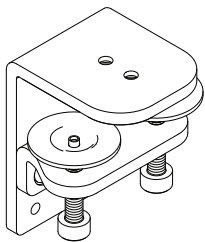

GROMMET CLAMP AC-GC

