



Ceiling mount **TH-1026-CT**

For an affordable yet professional display, the TH-1026-CT ceiling mount is ideal for small screens weighing up to 15kg (33lbs). Everything you need to create a professional finish is included – internal cable management, flexible pole adjustment and quick display attachment mechanism. Ideal for surveillance systems, demonstration or point of sale, this ceiling mount is specifically designed for easy installation, with the quick attachment system and security screw to protect screen safety. The telescopic pole can be rotated through a full 360° with the ability to tilt the screen to a perfect viewing angle.

 Mounting hole pattern:
75x75mm
100x100mm

 Maximum weight carrying capacity:
15kg (33lbs)



Product key features:

- Durable steel construction
- Designed for quick and easy installation
- Can be attached to masonry or timber ceilings
- Adjustable tilt: 0° of up and 15° down
- Adjustable pole length: from 940mm (37") to 1595mm (62.8") in 50mm (1.97") increments
- All mounting hardware included



Adjustable tilt: 0° of up and 15° down

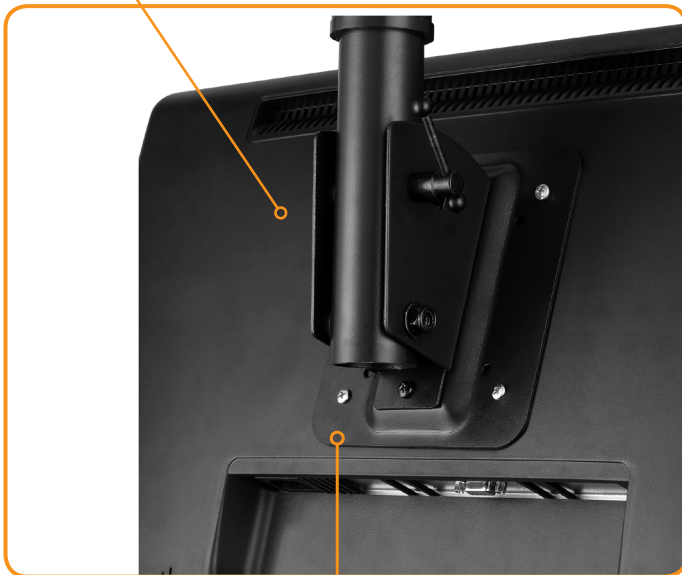

Quick attachment system for easy display attachment/removal with security screw

Pole can be rotated 360°

Adjustable pole length: from 940mm (37") to 1595mm (62.8") in 50mm (1.97") increments

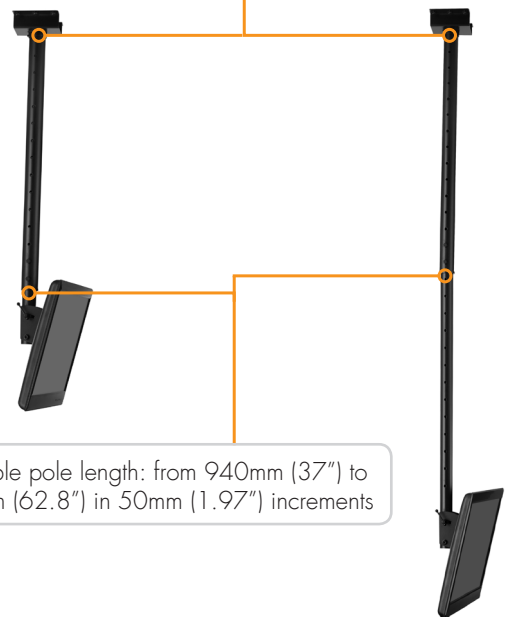

Product information

Product Code	Load capacity	Material	Colour
TH-1026-CT	15kg (33lbs)	Powder coated steel	Black

Package information, single unit

Size (L x W x H)	Ship weight	UPC code	Contents
99cm x 19.5cm x 10cm (38.2" x 9.3" x 4.3")	5.5Kg (12.1lbs)	881493007482	All hardware required for installation supplied

Package information, master pack

Size (L x W x H)	Ship weight	UPC code	Units per master pack
100cm x 31cm x 21cm (38.4" x 10.8" x 9.8")	16.5Kg (36.3lbs)	881493007499	3

Technical drawings

CEILING MOUNT

The Ceiling Mount can be mounted to either:
Timber Stud Ceiling or Masonry Ceiling

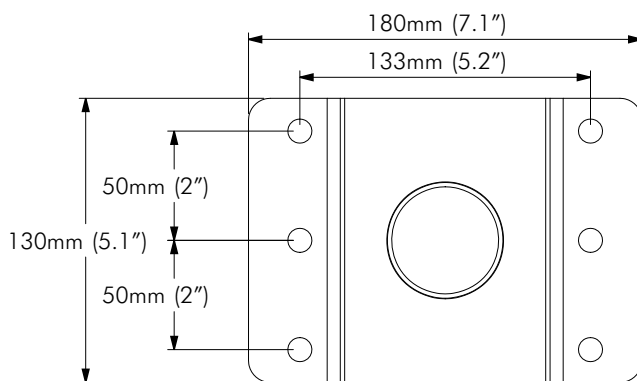

SCREEN MOUNTING COMPATIBILITY

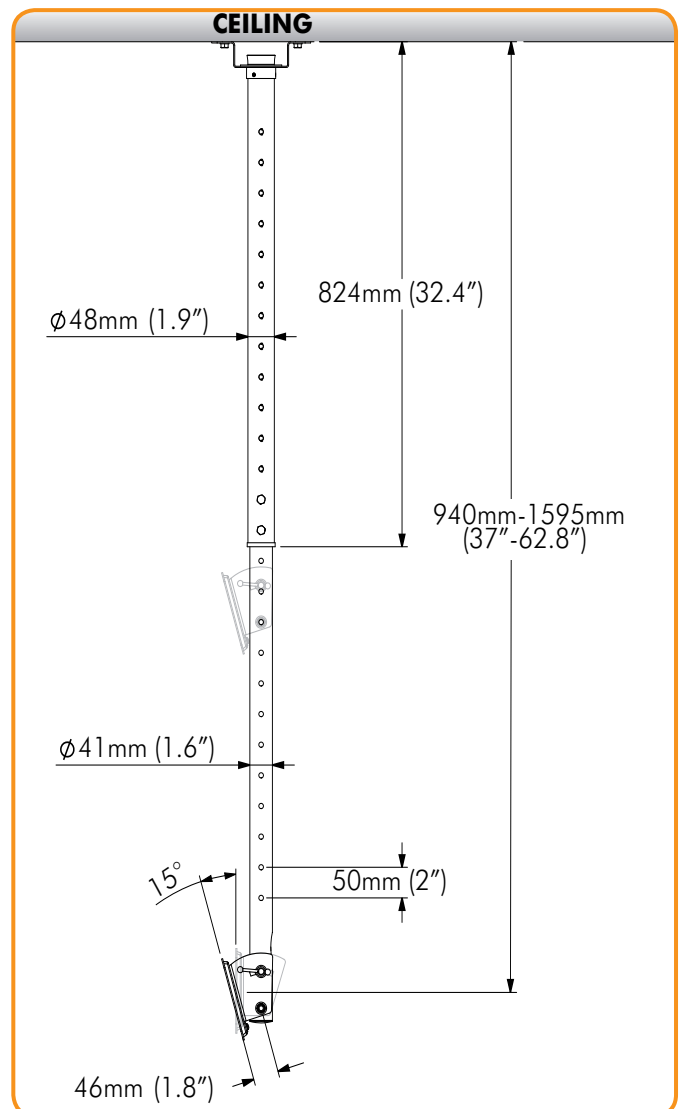
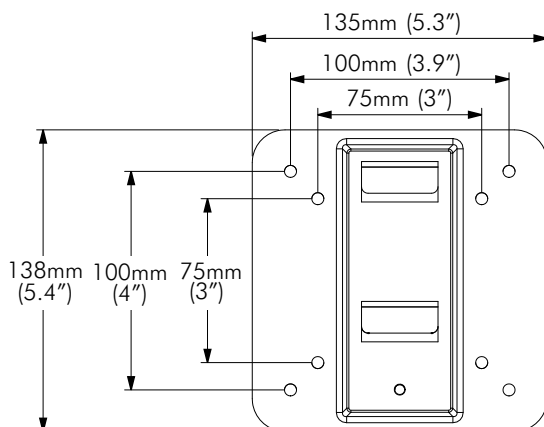

Atdec mounts are designed, developed and tested in Australia. We manufacture an extensive range of display and projector mountings for a variety of user types and situations. While all efforts have been made to ensure the information in this brochure was correct as of the date of printing, we reserve the right to change specifications without notice. Please refer to the website for our full range along with the latest details on specifications, compatibility and dealer location. Atdec and Telehook are registered trademarks with all rights reserved. Copyright July 2012.