

Component Checklist

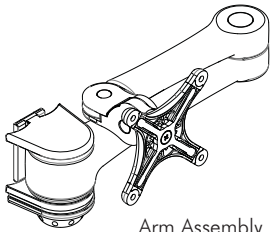

Arm Assembly



Primary Arm
Cable Cover

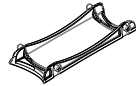

Secondary Arm
Cable Cover



End Cap

Tools Required:

- Power Drill
- 5.5mm (1/4") Drill Bit
- 8mm (5/16") Drill Bit
- Phillips Head Screwdriver

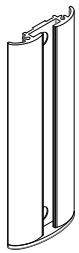

Wall Plate

HARDWARE



2.5mm
Allen Key

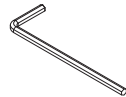

5mm
Allen Key



Nylon Anchor
Plug (x2)



M4 x 12mm
Countersunk
Screw (x2)



M6 x 50mm
Countersunk
Screw (x2)

Display Mounting Screws



M4x10/12/16mm (x4)
Phillips Head
Mounting Screws

IMPORTANT INFORMATION:

! IMPORTANT - Install Focus Articulated Arm Wall as per installation instruction.

! This product supports a maximum load of 8kg (17.6lbs).

! The manufacturer accepts no responsibility for incorrect installation.

Step 1. Check Components

Check what you have received against the component checklist and hardware above.

Step 2. Position Wall Plate

As a guide, it is recommended that the bottom of the Wall Plate be positioned approximately 140mm (5 1/2") above the desktop.

For further Ergonomic Guidelines, please refer to the end of the document.

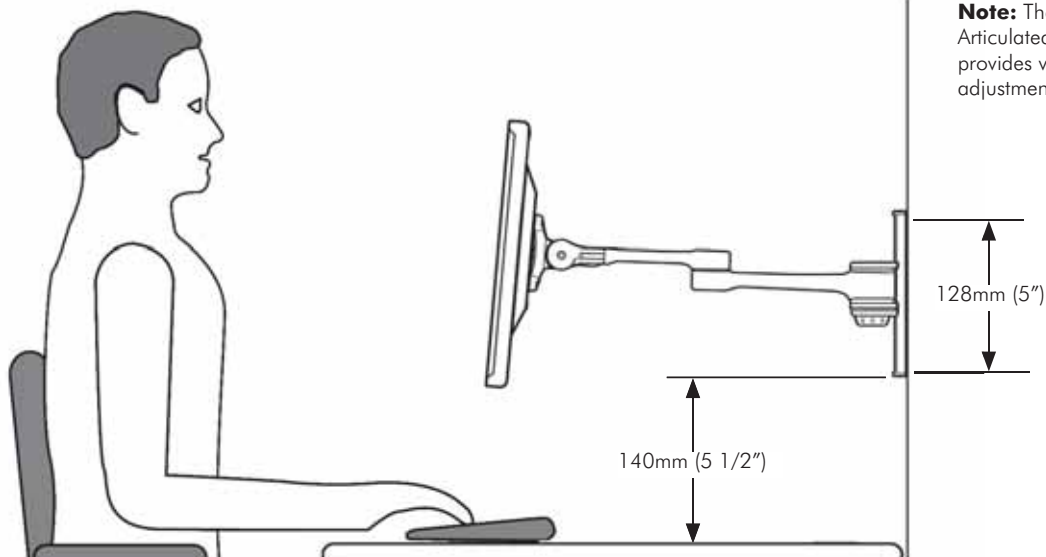

Note: The Focus Articulated Arm Wall provides vertical adjustment of 128mm.

Step 3. Installing the Wall Plate

3.1 Choose the appropriate installation procedure depending on your wall type.

Masonry

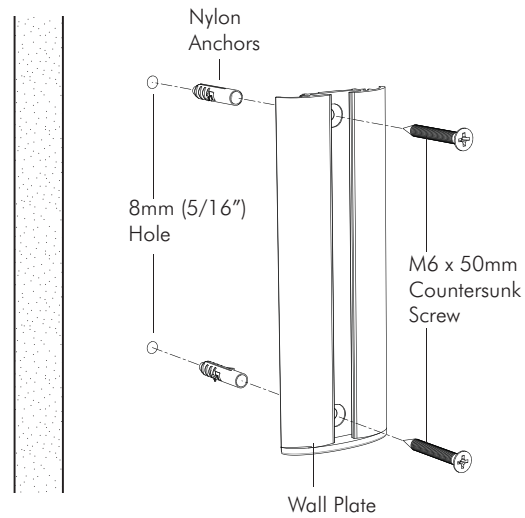

Timber Stud

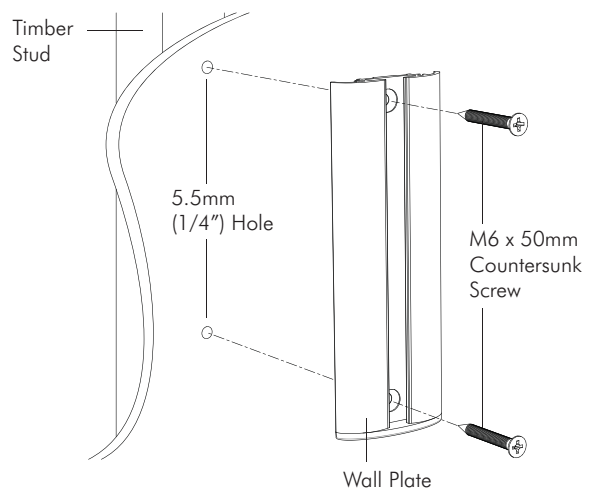

Step 4. Mount Arm Assembly

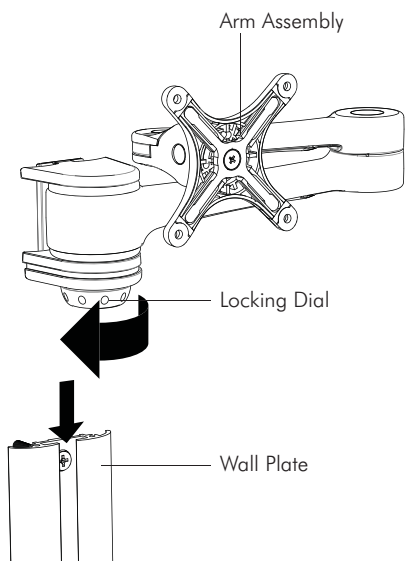

4.1 Unlock the Locking Dial before inserting the Arm Assembly into the Wall Plate.

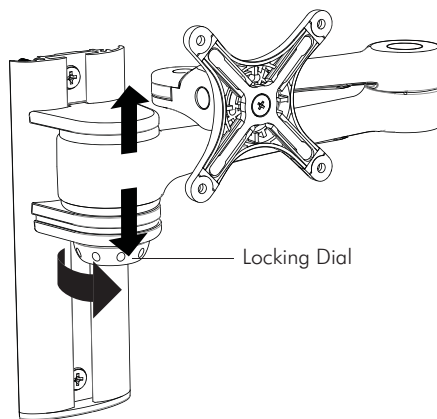
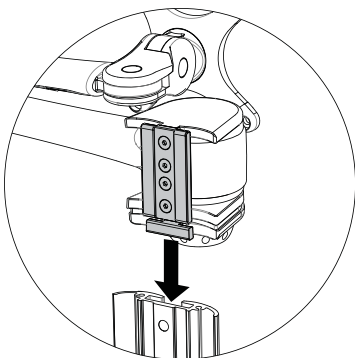

4.2 Slide the Arm Assembly to the preferred height and lock to secure the arm.

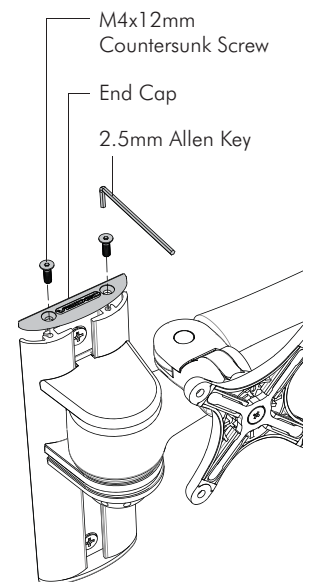
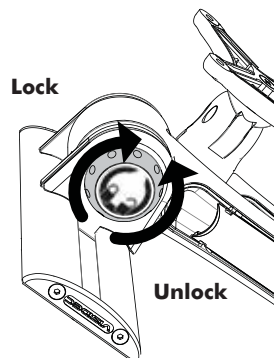

4.3 Secure the End Cap with the supplied M4x12mm Countersunk Screws and 2.5mm Allen Key.

Step 5. Mount Display

Option 1: 75x75mm Hole Pattern

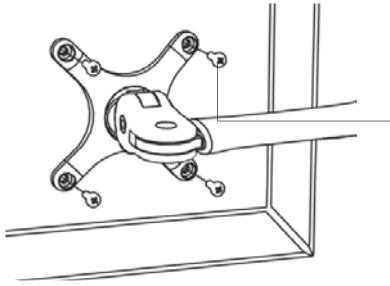

M4 Phillips Head
Mounting Screws

Option 2: 100x100mm Hole Pattern

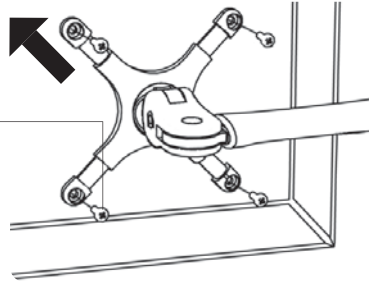

Note: Extend Arms to
achieve 100x100mm
hole pattern.

Step 6. Adjust Height

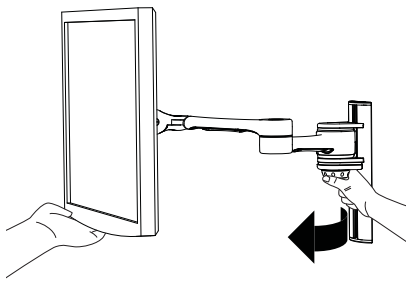

5.1 Unlock Lock Dial ensuring both Screen
and Arm Assembly are supported.

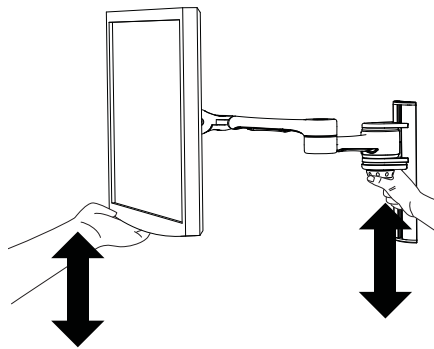

5.2 Lift/Lower Screen to the desired height.
Move both Screen and Arm assembly together.

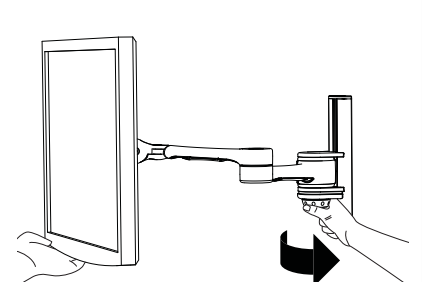

5.3 Lock the Lock Dial firmly.

Step 7. Cable Management

7.1 After plugging in your cables, install the Cable Covers.

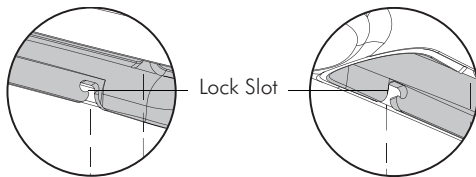

A. Insert Cable Covers up
into Lock Slots.

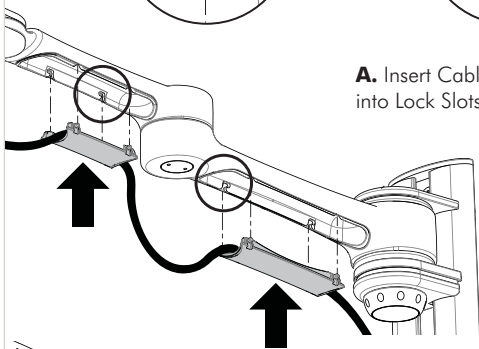

B. Push Cable Covers away
from Elbow Joint to secure
in place.

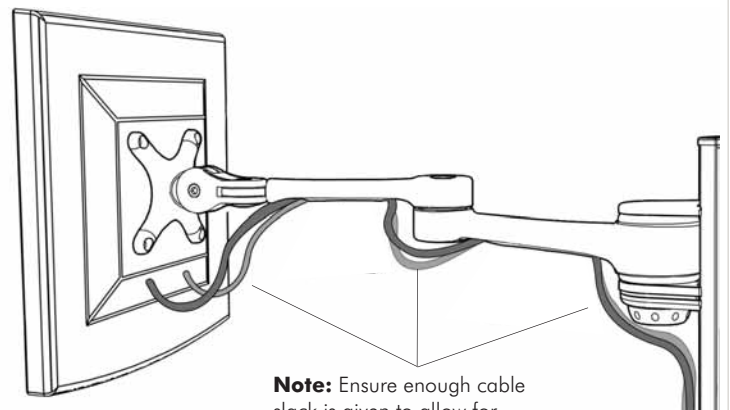
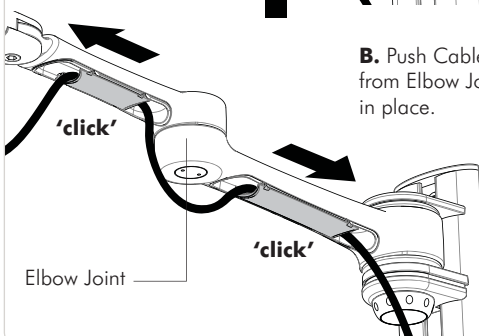

Note: Ensure enough cable
slack is given to allow for
movement.

Step 6.2. Insert Cable Stops

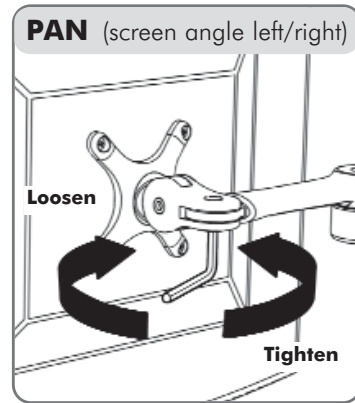
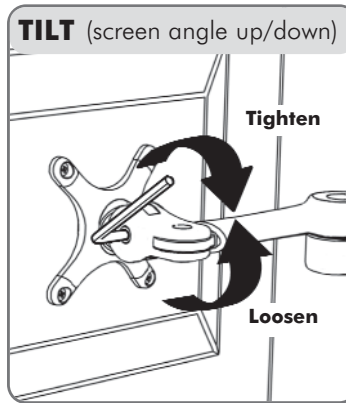
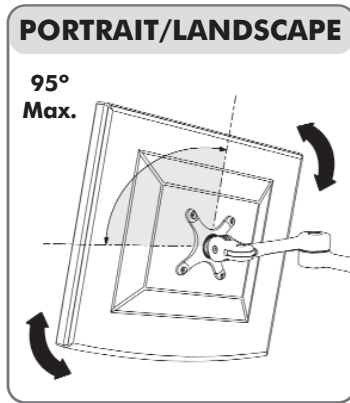

Ergonomic Guidelines

Many experts believe that the extended use of any computer screen has the potential to cause serious injury to your eyes, neck and back. This can be largely avoided by correctly positioning your display.

Viewing angle: Ergonomists recommend that the optimal position of your display should be slightly below eye level. When looking at the display's centre the user should have a downward visual angle of approximately 10°-20°.

Height: As a guide, the height (**h**) of your display should approximately be as follows:

- Tall Male (Max): 560mm (22")
- Short Male (Min): 368mm (14.5")
- Tall Female (Max): 520mm (20.5")
- Short Female (Min) 356mm (14")

Distance: For visual comfort, a viewing distance (**d**) between 500mm (20") to 750mm (29.5") is recommended.

Tilt Angle: Angular adjustments to reduce reflection on your monitor should range between 5° forward tilt to 15° backward tilt.

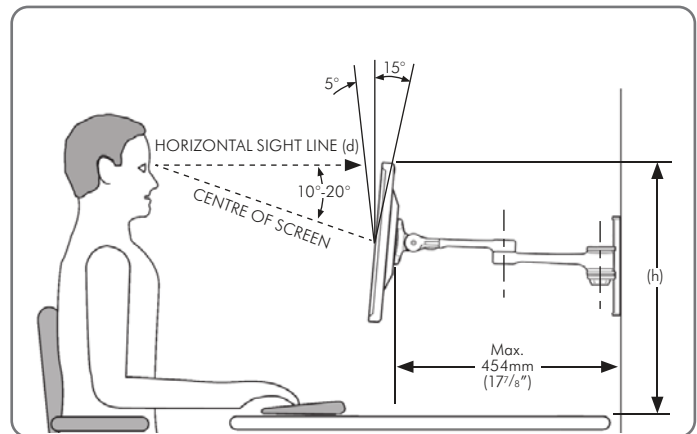

Installation Complete